

SLIP CLUTCH-ADJUSTABLE

INTERMITTENT DUTY

**TORQUE RANGE
UP TO 10 OZ.-IN.**

PIN HUB TYPE

ORDER BY CATALOG NUMBER

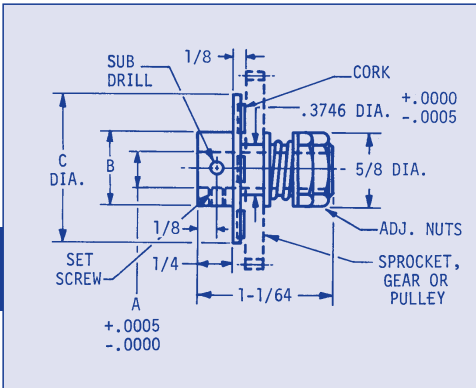

Set Screw	A	B	C	Cat. No.
#2-56	.1248	.312	5/8 1	EUS-D2-1 EUS-D2-2
#4-40	.1873	.375	5/8 1	EUS-D2-3 EUS-D2-4
#6-32	.2498	.500	5/8 1	EUS-D2-5 EUS-D2-6

For light duty only - not to be used for continuous duty. Standard units adjustable to 10 oz. in. for adjustment from 10 to 50 oz. in., add -50 to catalog number.

Material: Stainless steel

CLAMP TYPE

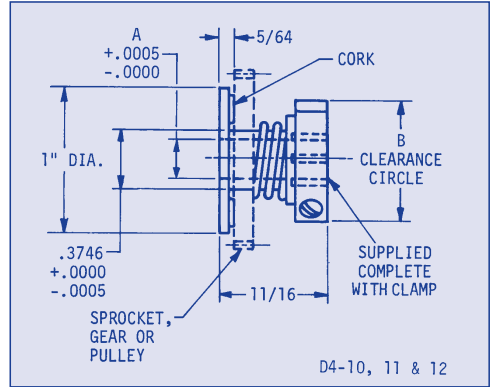
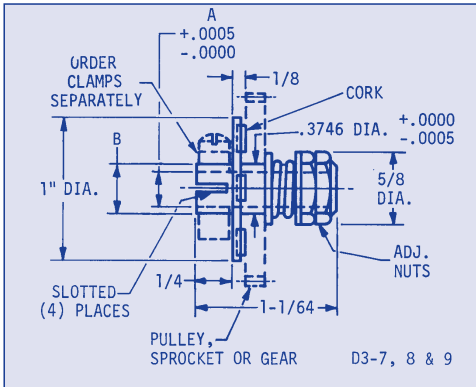

Material: Stainless steel

ORDER BY CATALOG NUMBER

A	B	Cat. No.
.1248	.188	EUS-D3-7
.1873	.250	EUS-D3-8
.2498	.312	EUS-D3-9

A	B	Cat. No.
.1248	7/8	EUS-D4-10
.1873	1-1/32	EUS-D4-11
.2498	1-1/8	EUS-D4-12

For light duty only - not to be used for continuous slip.

Note - for use with hubless gears, chain sprockets, timing belt pulleys, gear blanks.

35E (800) 243-0986
In CT (203) 775-4877

NORDEX